

CARSONITE PRODUCT SPECIFICATION FOR UTILITY MARKER (CUM-375)

1 SCOPE

This specification covers the minimum material, mechanical and performance requirements of Carsonite's continuous glass fiber and resin reinforced CUM-375 Composite Marker. This product may be used to provide daytime and nighttime delineation for utilities or other marking applications requiring assured long-term outdoor durability, vandal resistance, and vehicle impact resistance.

2 GENERAL REQUIREMENTS

2.1 DESIGN

The CUM-375 Marker shall be a single piece marker capable of simple, permanent installation by one person using a manual driving tool. The CUM-375 upon proper installation shall resist displacement from wind and vehicle impact forces. The CUM-375 shall be of a constant flat "T" cross sectional design with reinforcing support ribs incorporated longitudinally along each edge to provide sheeting protection and structural rigidity. The bottom end of the marker shall be pointed for ease of ground penetration.

2.2 MATERIAL

The CUM-375 Marker shall be constructed of a durable, UV resistant, continuous glass fiber and resin reinforced, thermosetting composite material which is resistant to impact, ozone, and hydrocarbons within a service temperature range of -40°F to +140°F.

2.3 WORKMANSHIP

The CUM-375 Marker shall exhibit good workmanship and shall be free of burns, discoloration, cracks, bulges or other objectionable marks which would adversely affect the marker's performance or serviceability.

2.4 MARKING

Each CUM-375 shall be permanently identified with the manufacturer's name and the month and year of fabrication. The letters shall be a minimum of 3/8-inch in height, and permanently affixed to the rear of the marker. A black line shall be stamped horizontally across the front of the marker near the bottom to indicate proper burial depth.

3 PHYSICAL AND MECHANICAL REQUIREMENTS

3.1 DIMENSIONS

The CUM-375 Marker shall conform to the shape and overall dimensions shown in Figure 1.

3.1.1 Width

The nominal CUM-375 Marker width shall be 3.75 inches in order to accommodate a three-inch wide reflector and provide adequate daytime delineation.

3.1.2 Length

The CUM-375 shall be of such length to provide the required height above the road surface with a minimum embedment depth of 18 inches.

3.2 MECHANICAL PROPERTIES

The CUM-375 shall have the minimum mechanical properties as follows:

<u>PROPERTY</u>	<u>ASTM TEST METHOD</u>	<u>MINIMUM VALUE</u>
Ultimate Tensile Strength	D-638	50,000 psi
Ultimate Compressive Strength	D-638	45,000 psi
Specific Gravity	D-792	1.7
Weight % Glass Reinforcement	D-2584	50%
Barcol Hardness	D-2583	47

3.3 COLOR FASTNESS

The CUM-375 shall be pigmented throughout the entire cross-section so as to produce a uniform color, which is an integral part of the material. Ultraviolet resistant materials shall be incorporated in the construction to inhibit fading or cracking of the delineator upon field exposure.

3.4 DEFLECTION

Deflection tests shall consist of a two-pound load suspended from one end of the CUM-375 while the other end is clamped to a support in cantilevered fashion, Horizontally, the distance from the fulcrum to the weight shall be 48 inches. The maximum allowable free end deflection shall be ten inches.

3.5 TEMPERATURE RESISTANCE

3.5.1 Hot Resistance/Flexibility

A four foot CUM-375 Marker shall be conditioned for a minimum of two hours at $140^{\circ}\text{F} \pm 3^{\circ}\text{F}$. The unit shall then be held at the bottom end in a vertical position and the top end bent 90° such that it parallels the floor. The marker shall return to within 5° of the upright position within 30 seconds. The bend test shall be repeated three times in quick succession, completing the test within 2.5 minutes of post removal from the conditioning temperature.

3.5.2 Cold Resistance/Flexibility

A four foot CUM-375 Marker shall be conditioned for a minimum of two hours at $-40^{\circ}\text{F} \pm 3^{\circ}\text{F}$. The unit shall then be held at the bottom end in a vertical position and the top end bent 90° such that it parallels the floor. The marker shall return to within 5° of the upright position within 30 seconds. The bend test shall be repeated three times in quick succession, completing the test within 2.5 minutes of post removal from the conditioning temperature.

3.5.3 Cold Impact Resistance

The CUM-375 shall be conditioned a minimum of two hours at $-40^{\circ}\text{F} \pm 3^{\circ}\text{F}$. A minimum two-pound spherical weight shall be dropped a distance of five feet through a virtually frictionless vertical guide to impact the surface of the marker at mid section. The surface of the post being struck by the steel ball shall be in a horizontal position with the post supported and held in position at both ends. The post shall be subjected to five impact tests concentrated near the middle of the post within 10 minutes from the removal from the environmental chamber. Fracturing, cracking, or splitting of the posts shall constitute failure.

Another marker shall be struck flush against a flat solid surface three times within two minutes after removal from the conditioning chamber. To strike the marker it should be manually swung through a 90° arc, and the marker shall not fracture or shatter upon impact.

3.6 VEHICLE IMPACT RESISTANCE

The Carsonite CUM-375 Marker shall be capable of self-erecting and remain functional after being subjected to a series of ten head on impacts by a typical passenger sedan at 35 m.p.h. The CUM-375 shall retain a minimum of 60% of its sheeting.

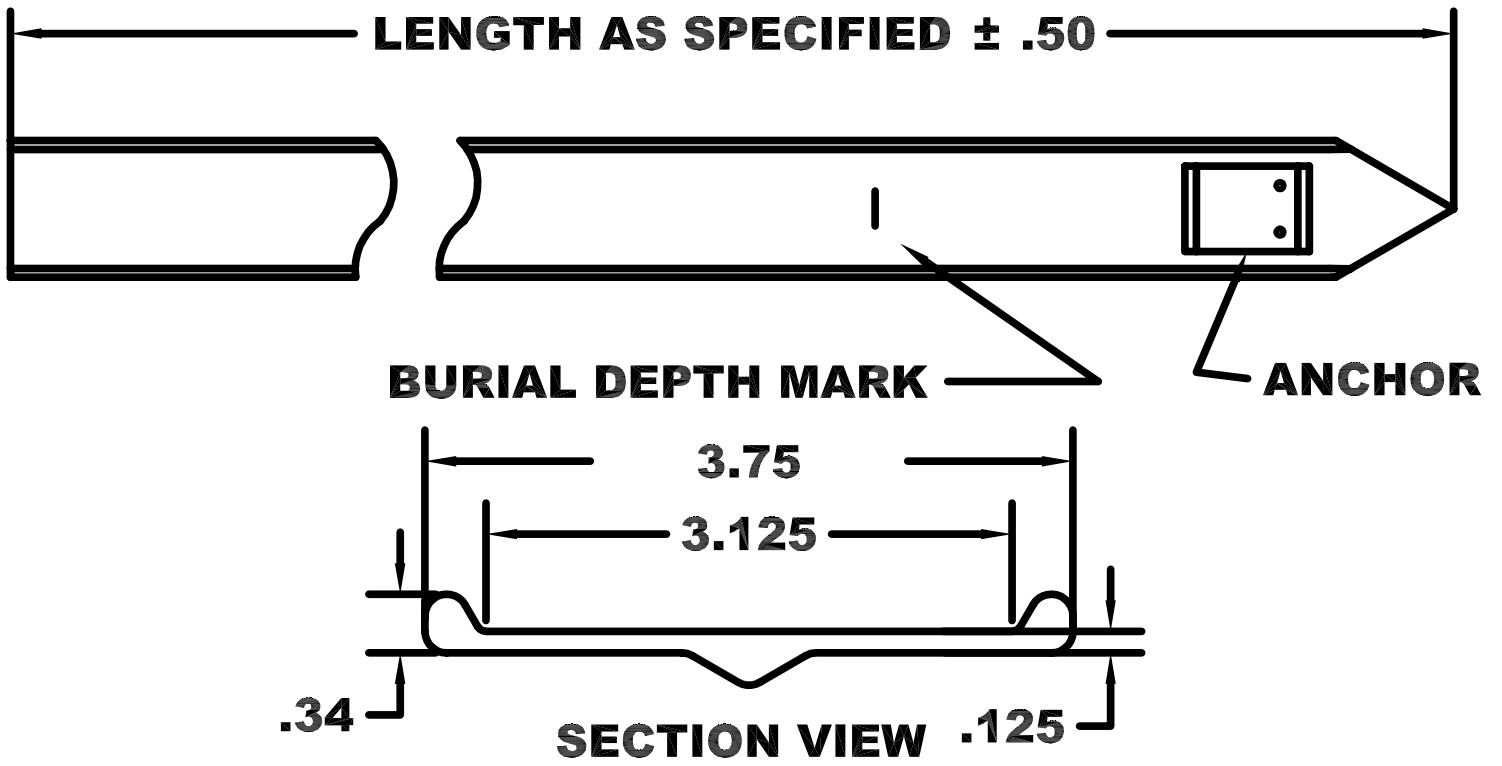

FIGURE 1