

Product Specification

HIGH PERFORMANCE ROADMARKER (CRM375)

1. SCOPE

This specification covers the requirements for materials of construction, performance, installation, and maintenance for Carsonite's glass reinforced composite RoadMarker™ (CRM375). The RoadMarker may be used to provide daytime and nighttime delineation for roadways or other marking applications requiring assured long-term durability, lightweight, flexibility, and vehicle impact resistance.

2. DESIGN

The RoadMarker is a single piece marker capable of simple, permanent installation by one person using a manual driving tool. The RoadMarker, upon proper installation, can resist displacement from wind and vehicle impact forces. The RoadMarker has a constant flat "T" cross sectional design to accept retroreflective sheeting/decals with reinforcing support ribs along its edges to provide protection of the sheeting. An additional reinforcing rib runs down the back side of the post to provide additional rigidity to the post.

3. MATERIAL

The RoadMarker is constructed of a durable, UV resistant, continuous glass fiber and resin reinforced, thermoset composite material which is resistant to impact, ozone, and hydrocarbons within a service temperature range of -40° F to +200° F.

4. SHEETING

Sheeting is specified by the ordering agency.

5. MARKING

Each RoadMarker is permanently identified with the Carsonite's name, month, and year of fabrication. A black line is stamped horizontally across the front of the marker to indicate proper burial depth.

6. DIMENSIONS

The RoadMarker conforms to the shape and overall dimensions shown in Figure 1 below. Length of post is determined by ordering agency.

7. MECHANICAL PROPERTIES

PROPERTY	ASTM TEST METHOD	MINIMUM VALUE
Ultimate Tensile Strength	D-638	50,000 psi
Ultimate Compressive Strength	D-638	45,000 psi
Specific Gravity	D-792	1.7
% Glass Reinforcement	D2584	50%
Barcol Hardness	D2583	47

8. PACKAGING

Length (in.)	Weight (each)	Quantity/Box	Boxes/Pallet
60	2.3	20	15
72	2.8	20	15
84	3.2	20	15
96	3.7	20	15

Note: When ordered with anchors attached, 10/box

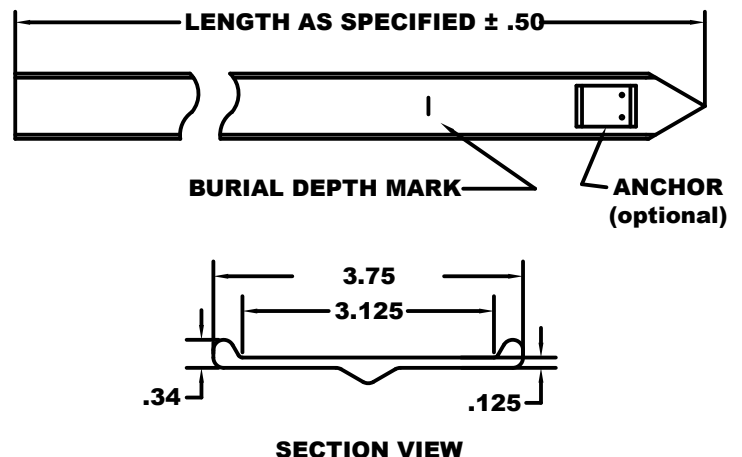

FIGURE 1

Carsonite Composites

19845 U.S. Highway 76, Newberry, South Carolina 29108
 Toll-free: 1-800-648-7916 · Fax: 803-276-8940
www.carsonite.com