

## Product Specification

### TUFF-FLEX™ (CTFM)

#### 1. SCOPE

The Scope of this specification covers the minimum requirements for the Carsonite Tuff-Flex™ Marker (CTFM). This product is designed as an identification marker for buried utility services and may be used to provide daytime and nighttime delineation for roadways or other marking applications requiring long-term durability, lightweight, flexibility, and vehicle impact resistance.

#### 2. DESIGN

The Tuff-Flex Marker is a single piece marker capable of simple, permanent installation by one person using a manual driving tool. The Tuff-Flex upon proper installation shall resist displacement from wind and vehicle impact forces. The Tuff-Flex has a thickened center section to enhance driveability while allowing sheeting or decals to easily be applied to both surfaces. Reinforcing support ribs are incorporated longitudinally along each edge to provide sheeting protection and structural rigidity. The bottom end of the marker is pointed for ease of ground penetration.

#### 3. MATERIAL

The material is a glass and resin reinforced thermosetting composite which is resistant to vandalism, impact, ultra violet light, ozone, and hydrocarbons and which is temperature resistant from -50° F to +200° F.

#### 4. SHEETING

Sheeting is specified by the ordering agency.

#### 5. MARKING

Each Tuff-Flex Marker is stamped horizontally across the front of the marker to indicate proper burial depth.

#### 6. DIMENSIONS

The Tuff-Flex marker conforms to the shape and overall dimensions shown in Figure 1 below. Length of post is determined by ordering agency.

#### 7. MECHANICAL PROPERTIES

PROPERTY	ASTM TEST METHOD	MINIMUM VALUE
Ultimate Tensile Strength	D-638	50,000 psi
Ultimate Compressive Strength	D-638	45,000 psi
Specific Gravity	D-792	1.7
% Glass Reinforcement	D2584	50%
Barcol Hardness	D2583	47

#### 8. PACKAGING

Length (in.)	Weight (each)	Quantity/Box	Boxes/Pallet
60	3.0	20	15
72	3.6	20	15
84	4.2	20	15
96	4.8	20	15

Note: When ordered with anchors attached, 10/box

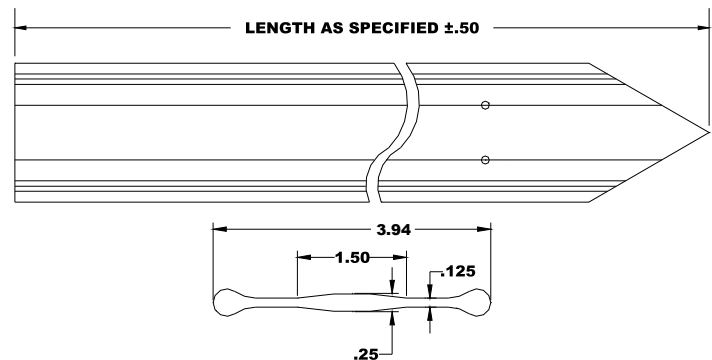

SECTION VIEW

FIGURE 1

## Carsonite Composites

19845 U.S. Highway 76, Newberry, South Carolina 29108  
 Toll-free: 1-800-648-7916 · Fax: 803-276-8940  
[www.carsonite.com](http://www.carsonite.com)